

# MODEL RGS-2D REMOTE GALVANOMETER SCANNER

## FEATURES :

- HIGH SPEED TWO AXIS (X - Y) LASER SCANNER UNIT, CLASS IIIA CDRH CERTIFIED.
- AUTONOMOUS DISPLAY OPERATION OR REMOTE CONTROL BY EXTERNAL SIGNAL SOURCE.
- PROFESSIONAL QUALITY, PROMPT DELIVERY, AND PROVEN RELIABILITY

The RGS-2D Remote Galvanometer Scanner is a low powered laser display system based on a solid state laser, a pair of high precision X and Y axis scanners, and a computer micro-controller. The unit creates bright and stable displays of line art images or animation by rapid modulation and deflection of the laser output.

The unit can be programmed as a "stand-alone" display system with either fully independent operation, manual control using a small pendant, or computer control through an RS-232 serial port. The on-board animation processor has up to 4 megabytes of non-volatile "Flash" memory storage, which is enough capacity for thousands of static images, or several minutes of animated laser graphic displays.

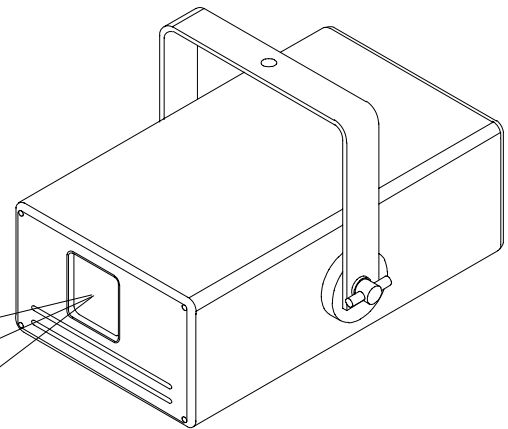

P.P.S.

The RGS-2D unit is housed in a rugged, black anodized aluminum case measuring a compact 11 x 6 x 4.5 inches. The housing contains the laser, the X - Y scanner pair, the power supply, the scanner drivers, and the animation processor. The scanning optics can be configured with either GSI Lumonics G-120, G-138, or Cambridge Technology 6800 series galvanometers. The entire internal chassis assembly can be removed from the outer enclosure for ease of maintenance..

## APPLICATIONS:

- Point of Sale Displays
- Programmable Signage
- Industrial Parts Alignment
- Entertainment Productions

The unit operates from 120 or 240 volt, 50/60 Hz AC power. Image programming may be created using the advanced *LaserCAD* software package for animated displays, or derived from DXF drawing data files for alignment applications. The unit features three mounting options: A yoke for overhead mounting like a lighting instrument, a single point mount for a standard camera tripod, or a set of fixed attachment points for stability in lock-down industrial installations.



PRECISION PROJECTION SYSTEMS, INC.  
17508 STUDEBAKER ROAD, CERRITOS, CA 90703  
TEL 562 865-8552 FAX 562 924-7133  
EMAIL: info@ppsf.com

# SPECIFICATIONS

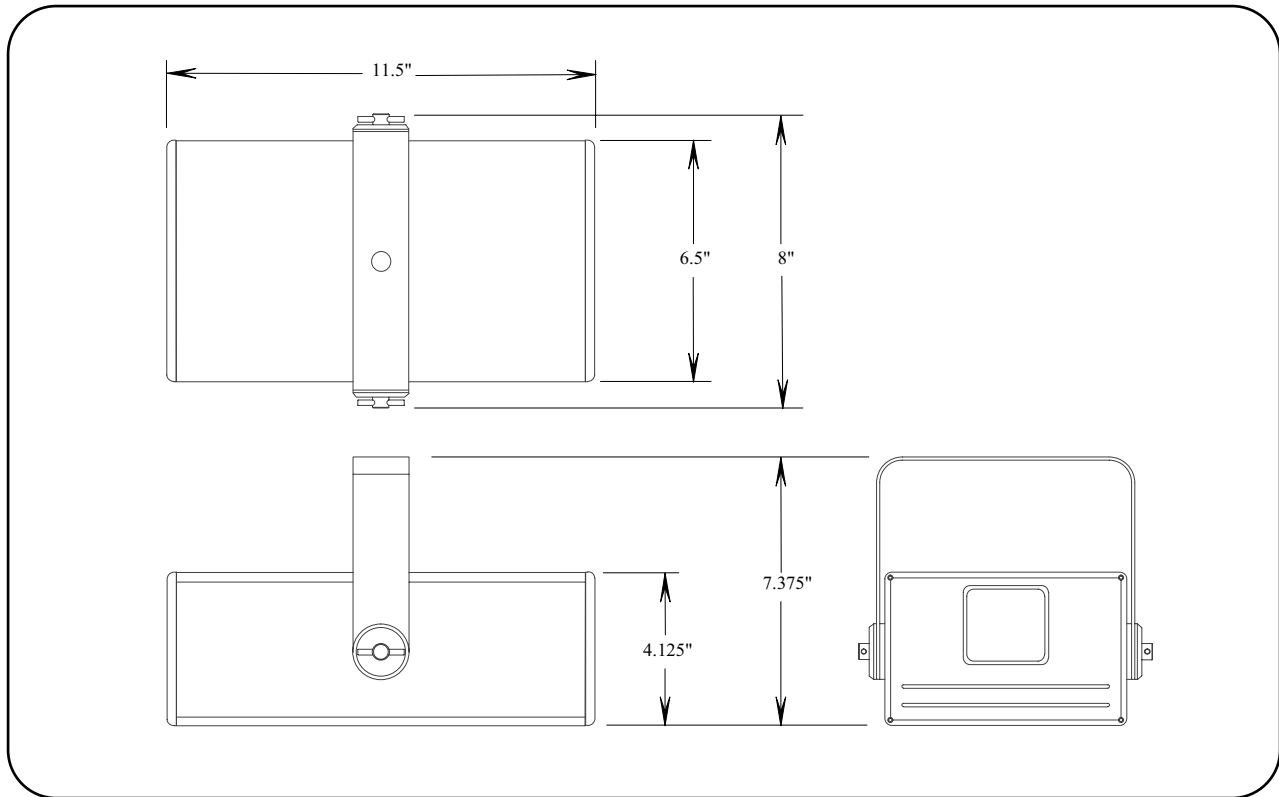

## OPTICAL

Laser: 5 Milliwatt Class IIIa Red or Green Solid State Laser  
Wavelength: 650 nanometer red, 532 nanometer green  
Deflection Angle:  $\pm 20^\circ$  Optical, or 70 % of distance  
Optional Wide Angle:  $\pm 40^\circ$  Optical or 120 % of distance  
Accuracy: Typically .2% or  $\pm .1$  inch on a 100 inch field

## MECHANICAL

Housing: Extruded Aluminum  
Finish: Black Anodized  
Yoke: 1.50" x 1.25" Aluminum  
.5" Dia. mounting hole  
Weight: 10 lbs. (3.7 Kg.)

## ELECTRICAL

Line Voltage: 120 / 240 VAC, 50 / 60 Hz @ 1 amp  
Serial Port: RS-232, DB-9M, 9600,N,8,1 default  
X or Y Input:  $\pm 10$  VAC maximum  
Blanking Input: 0 to 5 volt TTL level

## OPTIONS & ACCESSORIES

*LaserCAD* graphics and animation programming software  
*LaserCAD* DXF interpreter and display calibration software  
Custom Image or animation programming, customer specified  
Specialty optics for high accuracy alignment applications  
Multi-color option for distinctive or specialized displays



PRECISION PROJECTION SYSTEMS, INC.  
17508 STUDEBAKER ROAD, CERRITOS, CA 90703  
TEL 562 865-8552 FAX 562 924-7133  
EMAIL: info@ppsfx.com